

BOARD OF TRUSTEES
 Allen M. Freeman
 Nicholas J. Kelly
 Peter J. Kambelos, MD

Fiscal Officer
 Debbie S. Schwey

Administrator
 Loretta E. Rokey



SERVICE DEPARTMENT
DIRECTOR
 John Koehler

950 Locust Corner Road
 Cincinnati, Ohio 45245

(513) 947.2021
 Fax # (513) 752.8418

Road Cut Permit Fee is \$50.00 payable to Pierce Township
 Permit # _____

APPLICATION FOR WORK PERFORMED IN TOWNSHIP PUBLIC RIGHT OF WAY

(Please Print Clearly)

It is understood that this application does not constitute permission to do work within the right-of-way, but is only an application for a permit for this job. Please allow 5-10 working days for an inspection of the working site. In some cases, permits are issued with changes to the original application and site plans. **DO NOT BEGIN** work until permit has been received and reviewed. The permit must be available on site and in contractor's possession. Permit is valid for one year after issuance.

Date of Application: _____ Initial states you have read _____

Contractor's Name: _____ Telephone Number: _____

Company Address: _____
 Street Address City State Zip Code

24 Hour Contact: _____ Emergency Number: _____

Project Location:

N
 W E Side of _____ Street, at No. _____ or _____ feet
 S

N
 W E from its intersection with _____ Street or Road
 S

Excavation in Right of Way: Road Cut Bore Tunneling Other: _____

Type of Pavement: Asphalt Concrete Composite Other

Type of Curb: Concrete Roiled Concrete Vertical Asphalt None

Opening Length _____ Width _____ Depth _____

Purpose: _____

Duration of Excavation: Estimated Start Date: _____ **Estimated Completion Date:** _____

Is this application made before excavation? Yes _____ No _____ (If no, please complete the following)

When was the work performed and by whom: _____

Permit Application Checklist:

Every application submitted for a permit shall address the following items on the plans for review by the Pierce Township Service Department Director or their representative. Applicants shall check off each item provided on the application and plans and sign below. Attach a separate letter explaining reason why any item below is not provided for on the application or plans.

- A completed application with all the requested information.
- A detailed site plan.
- Copies of stamped plans issued from other Government agencies (if applicable)
 - Clermont County Sewer Stamped Date: _____
 - Clermont County Water Stamped Date: _____
 - Clermont County Engineer Stamped Date: _____

Road Cut – Bore – Tunneling

- General Liability Insurance Certificate, Performance/Maintenance Bond (\$100 per linear feet /3 feet of road edge)
- Provide a Traffic Control Plan, which complies with Ohio Manual of Uniform Traffic Control Devices. Plan shall show sign type and placement including distances from proposed excavation.
- Road Closures must be approved in writing by the Clermont County Engineer’s office.

Work Commencement Notice:

- I agree to notify Pierce Township Service Department at least two working days before the work is commenced by calling 513-947-2021
- I agree to 48 hours notification to the Ohio Utilities Protection Service at 1-800-362-2764, Clermont County Sewer & Water at 513-732-7943 (OUPS Locate Work Order included)
- I agree to 48 hour advance notice for inspections by calling 513-947-2021 between 7:30am and 3:00pm Monday through Friday.
- I agree to notify the following departments two working days before work is commenced of any street closure, parking restrictions, rerouting of traffic or other restrictions which may interfere with the normal use of the street:
 - Pierce Township Police 513-752-4100
 - Pierce Township Fire 513-752-6273
 - Clermont County Engineer 513-752-8857

I, the undersigned, understand that Pierce Township assumes no responsibility or liability for the work done under the permit and that all work shall be done at no cost to the Township. All work shall be done as applicable, in accordance with the laws of the State of Ohio, the Ohio Manual of Traffic Control Devices, OSHA Regulations, the Resolutions of the Trustees of Pierce Township and any supplemental and special provisions deemed necessary or as stated on the permit as special provisions or conditions. Pierce Township reserves the right to order the removal, reconstruction, relocation or repair of any work performed under a permit at the owner’s expense.

I hereby agree to all terms, conditions, and restrictions so far as they apply to work to be done under the permit as issued and general provisions listed above.

Contractor’s Signature: _____ Date: _____

Township Approved: _____ Date: _____

Permit #: _____

General Specifications

Road Cut - Bore – Tunneling

1. Give 24 hours' notice to the Service Director before work begins. Phone number 513-947-2021. RESIDENTS MUST BE GIVEN 24 HOURS NOTICE. Maintain at least one lane of traffic at all times. Complete closure of the road will not be permitted at any time except by written permission from the Clermont County Commissioner's or their appointed representative.
 2. Provide lights, signs, barricades and flaggers necessary to maintain safety in accordance with the Ohio Manual of Uniform Traffic Control Devices.
 3. Road Cuts: The outline of pavement cut shall be made with a saw to neat straight vertical lines. After the completion of the project BUT prior to Item 8 of these specifications, a T-Butt joint cut will be made 12" on both sides of the trench to a depth of "1 ½ - 2". All pavement replacement either (temporary or permanent) shall be made to meet existing surfaces when compacted and finished. (This procedure should help eliminate the washboard effect of road repairs.) (See Road Cut Diagram)
 4. Backfill specifications around pipe: Contractor shall contact appropriate agency. Clermont County Water and Sewer Specifications have precedent for pipe bedding and cover.
 5. Use compacted granular fill (ODOT item #304) in 6: lifts where the edge of the ditch, trench, or pit is within 3' of the edge of pavement.
 6. Backfill under road and within 3' of road edge: Light mortar, or flash fill with a finished surface of asphalt cold patch 2" in depth may be maintained by the contractor until weather permits the completion of items 7 and 8 of this specification.
 7. Asphalt sub-base 6" of (ODOT item 301 asphalt) in 2" lifts to within 2" of surface. Cold shall be required if asphalt 301 is not available.
 8. Finished surface of roadway with (ODOT spec. #404) 2" installed and edges shall be sealed with liquid asphalt. Road cut when left overnight must be steel plated or backfilled and cold patched. Steel plates must be firmly secured. Any road cut made between November 15th and April 15th must be temporarily patched with 2" of 405 bituminous cold mix before end of workday. Temporary patches must be maintained by the applicant until such time as the permanent patch can be placed and accepted by the Pierce Township Service Department Director or his representative.
 9. Right-of-way must be restored to "as good" or "better" condition. Proper drainage shall be maintained throughout project at all times. All ditches, slopes, drainage infrastructure, mailboxes, traffic signs, guardrail and sidewalks will be restored to County specifications (regardless of current condition). Ditches will be seeded or sodded as directed by the Township Inspector. Temporary seeding and erosion control may be required at the discretion of the inspector.
 10. (Bond) (Deposit) Attached in the amount of \$_____ to indemnify the Township against liability or damage as the result of such excavation and to guarantee the performance of all conditions of the permit, if issued. (Rate of Bond is \$100.00 per foot). Applicant must provide a copy of Insurance Certificate for the amount of \$1,000,000.00 to protect the Township against liability or damage as the result of such excavation.
 11. All OSHA regulations must be followed. A "COMPETENT PERSON" as defined by OSHA SHALL BE ON SITE WHILE TRENCHING.
 12. Roadways and Driveways shall be made passable by end of days' work.
 13. Pavement and berm will be kept clean of construction debris at all times. The contractor agrees to reimburse the Township for any clean up or installation of proper signs, barricades, flashers, and platting of the work site by the Township personnel. This includes mud tracked onto township roads.
 14. Materials stored in right-of-way are required to be properly barricaded and signed. Materials shall not be stored on the road surface.
 15. Loading and unloading of equipment and material from the roadway without protecting pavement will not be permitted. The Contractor will repair any damage to roadway.
 16. Contractor agrees to reimburse Pierce Township for the inspection of project after regular work hours or weekends.
 17. Other: _____
-
-

Open Road Cut

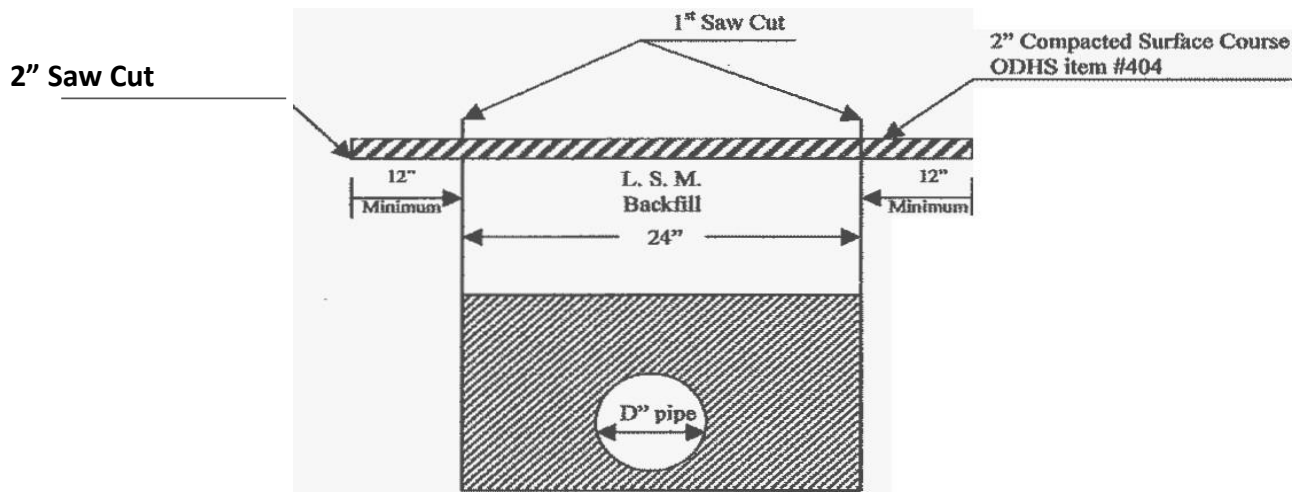

Gravel Backfill ODTS Item 410 Type A per County Water/Sewer Specification

Low Strength Mortar Cross Section

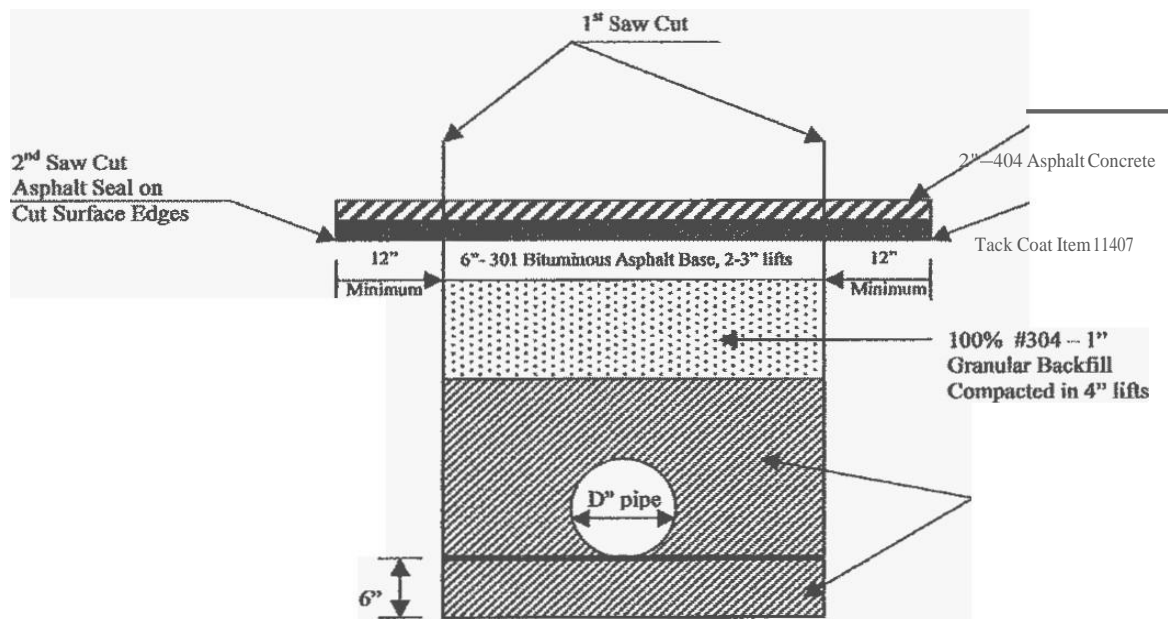

Note: The Pavement thickness indicated are indicated are minimum standards. If the pavement which is to be repaired has a greater thickness of asphalt, it shall be replaced in kind.

(Please keep for your records)